

# Investigation of Boiling Heat Transfer Characteristics of Two-Phase Closed Thermosyphons with Various Internal Grooves

**Ku-II Han**

*School of Mechanical Engineering, Pukyong National University,  
San 100, Yongdang-dong, Nam-ku, Pusan, 608-739, Korea*

**Dong-Hyun Cho\***

*Department of Mechanical Design Engineering, Daejin University,  
San #11-1, Sundan-ri, Pochun-eup, Pocheon-Gun, Kyonggi-Do, 487-711, Korea*

**Jong-Un Park**

*Department of Education, Pukyong National University, Busan,  
San 100, Yongdang-dong, Nam-ku, Pusan, 608-739, Korea*

The boiling heat transfer characteristics of two-phase closed thermosyphons with internal grooves are studied experimentally and a simple mathematical model is developed to predict the performance of such thermosyphons. The study focuses on the boiling heat transfer characteristics of a two-phase closed thermosyphons with copper tubes having 50, 60, 70, 80, 90 internal grooves. A two-phase closed thermosyphon with plain copper tube having the same inner and outer diameter as those of grooved tube is also tested for comparison. Methanol is used as working fluid. The effects of the number of grooves, the operating temperature, the heat flux are investigated experimentally. From these experimental results, a simple mathematical model is developed. In the present model, boiling of liquid pool in the evaporator is considered for the heat transfer mechanism of the thermosyphon. And also the effects of the number of grooves, the operating temperature, the heat flux are brought into consideration. A good agreement between the boiling heat transfer coefficient of the thermosyphon estimated from experimental results and the predictions from the present mathematical model is obtained. The experimental results show that the number of grooves and the amount of the working fluid are very important factors for the operation of thermosyphons. The two-phase closed thermosyphon with copper tubes having 60 internal grooves shows the best boiling heat transfer performance.

**Key Words :** Boiling, Internal Grooves, Heat Transfer Coefficient, Thermosyphon, Evaporator

## Nomenclature

$A$  : Heat transfer area ( $m^2$ )

$b$  : Distance between grooves (m)

$c_p$  : Specific heat ( $J/kg \cdot K$ )

$D_i$  : Inside diameter (m)

$D_o$  : Outside diameter (m)

$g$  : Gravitational acceleration ( $m/s^2$ )

$h$  : Heat transfer coefficient ( $W/m^2 \cdot K$ )

$h_{fg}$  : Latent heat of vaporization ( $J/kg$ )

$k$  : Thermal conductivity ( $W/m \cdot K$ )

$P$  : Pressure (Pa)

$q$  : Heat flux ( $W/m^2$ )

$T$  : Temperature (K)

$w$  : Width (m)

\* Corresponding Author,

E-mail : chodh@road.daejin.ac.kr

TEL : +82-31-539-1973; FAX : +82-31-539-1970

Department of Mechanical Design Engineering, Daejin University, San #11-1, Sundan-ri, Pochun-eup, Pocheon-Gun, Kyonggi-Do, 487-711, Korea. (Manuscript Received August 23, 2002; Revised July 30, 2003)

## Greek Letters

$\rho$  : Density ( $kg/m^3$ )

- $\mu$  : Dynamic viscosity ( $\text{N}\cdot\text{s}/\text{m}^2$ )  
 $\phi$  : Liquid fill charge ratio (%)

### Subscripts

- atm* : Atmosphere  
*e* : Evaporator  
*hot* : Heating water  
*l* : Liquid  
*sat* : Saturated  
*v* : Vapor

## 1. Introduction

Two-phase closed thermosyphon has many advantages such as a large amount of heat transfer capability using latent heat, uniform temperature distribution by vapor flow's heat diffusion, light and simple structure, fast heat response characteristics.

Many researches on thermosyphons have been performed due to these advantages since the principle of thermosyphon was suggested first by Gaugler (1942).

Such researches focused on pool boiling in evaporation section, liquid film boiling and working principle of thermosyphon based on its flow pattern, the improvement and the estimation of heat transfer coefficient. Imura et al.(1977) reported that the critical heat flow of thermosyphon is 1.2~1.5 times higher than that of heat pipe. Research on the heat transfer in the thermosyphon was also performed by Cohen and Bayley (1955) and followed by Larkin (1971), Lee and Mital (1972), Stret'stov (1975), Andros (1980), Kim et al.(1998), Lee and Lee (2001). They agree that heat transfer performance of two-phase closed thermosyphon is affected by working fluid, liquid fill charge ratio, inclination angle, internal diameter and length of thermosyphon, heat flux, working fluid vapor pressure. But plain tube was used in most of those studies and only a few research was performed using internal grooved tube. Heat pipe with internal triangular shaped groove was analyzed by Peterson and Ma (1996). A large effect for improving heat transfer rate is expected in thermosyphon when internal grooved tube is used.

Hong et al.(1998) carried out the research on the thermosyphon with internal grooves.

In this paper, experimental study on the vertical thermosyphons with various internal grooves was carried out. The heat transfer mechanisms at the evaporator were investigated experimentally and a mathematical model including the effects of the grooves, the operating pressure, the heat flux was developed.

## 2. Experimental Apparatus and Method

Fig. 1 shows the schematic diagram of the experimental apparatus. It consists of five parts such as test section, cooling water circulation line, heating water circulation line, high vacuum system, temperature measurement and recording system. Test section of the thermosyphon is illustrated in Fig. 2. The geometric specification of the plain and grooved thermosyphon is shown in Table 1. And 20 times enlarged cross sectional

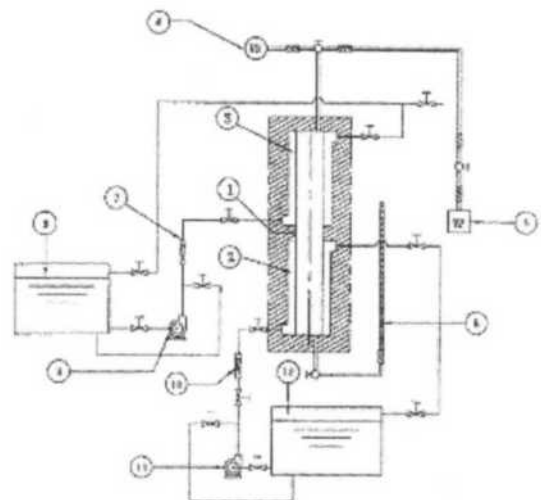

1. Test tube 2. Heating water chamber 3. Cooling water chamber 4. Vacuum gauge 5. Vacuum pump 6. Measuring device for liquid level 7. Coolant flow meter 8. Coolant pump 9. Coolant constant temperature bath 10. Heating water flow meter 11. Heating water pump 12. Heating water constant temperature bath

**Fig. 1** Cross-sectional view of the experimental two-phase closed thermosyphon

view of internal groove is shown in Fig. 3. The total length of the thermosyphon is 1200 mm. It consists of evaporation and condensation section with 550 mm in length respectively and adiabatic section with 100 mm in length. The test tube has a 14.3 mm inner diameter and a 15.8 mm outer diameter. Two 550 mm long water jackets are set on the test thermosyphon as mentioned above. One is used as a heating jacket for an evaporators and the other is used as a cooling jacket for a condenser. An inlet small tube for heating or cooling water flow into each jacket is directed at a tangent to the inside surface of the jacket. The thermosyphon can be positioned with any inclination angle from 0° to 90° with respect to the horizontal position. Nine Pt. 100 Ω thermocouples are soldered on the outside surface of the

tube along its length to measure surface temperatures.

Another nine Pt. 100 Ω thermocouples are inserted into the inside of thermosyphon to measure inside vapor temperatures. To measure the temperature distribution of working fluid in the test thermosyphon, a stainless tube of 2.0 mm o.d. was provided at the center of the thermosyphon. Nine

**Table 1** Geometric specifications of grooved thermosyphons

No.	Tube		Grooves		
	D <sub>o</sub> (mm)	D <sub>i</sub> (mm)	Number (No.)	Depth (mm)	Angle (°)
1	15.85	14.35	50	0.29	42
2	15.85	14.35	60	0.29	42
3	15.85	14.35	70	0.29	42
4	15.85	14.35	80	0.29	42
5	15.85	14.35	90	0.29	42

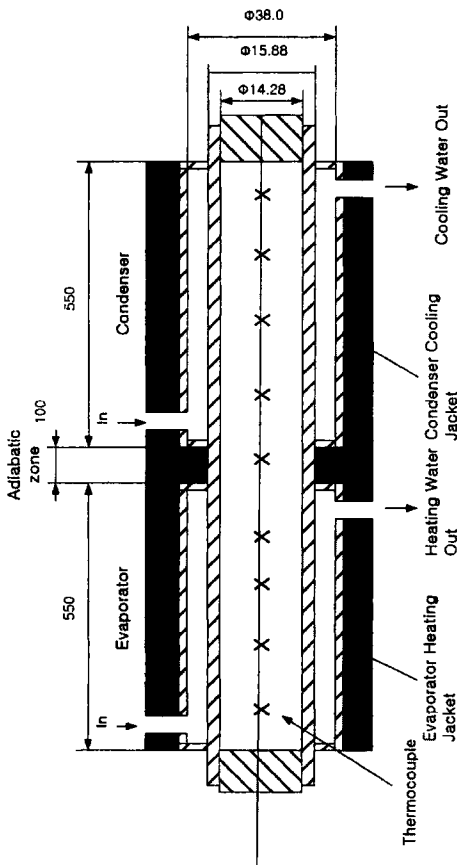

**Fig. 2** Cross-sectional view of the experimental two-phase closed thermosyphon

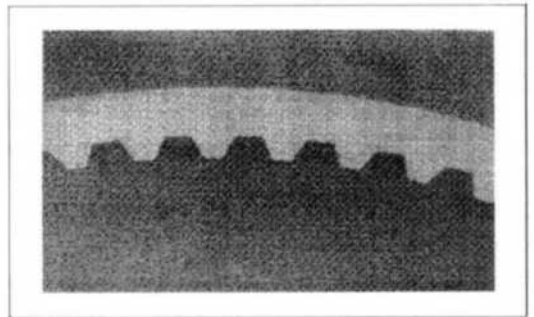
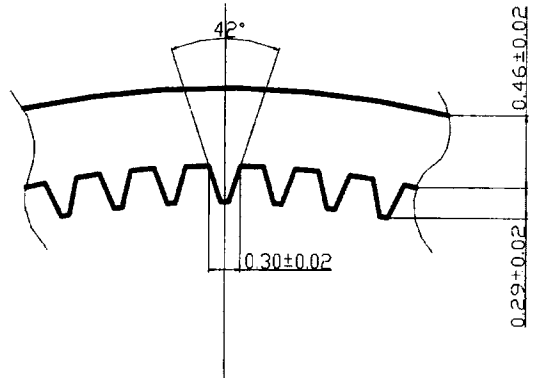

**Fig. 3** Enlarged cross-sectional view of internal grooves (60 grooves)

Pt. 100  $\Omega$  temperature sensors were arranged inside a stainless tube. The stainless tube was sealed hermetically. Four Pt. 100  $\Omega$  temperature sensors are placed at the inlets and the outlets of two water jackets. The temperature outputs are recorded on a data logger and it is connected to personal computer to analyze recorded data. A rotary vacuum pump and a diffusion pump with a rating of  $10^{-6}$  Torr are used to remove air and other non-condensable gases. Methanol is chosen as working fluid, since this is compatible with copper and safe materials to work with. Hashimoto et al. (1999) reported that the considerable decrease of condensation heat transfer might be caused by the non-condensable gases. In order to eliminate the non-condensable gases, a little more than exact quantity of working fluid is injected into the tube after evacuating air. After injecting the working fluid, heating and cooling water flow into the evaporator and the condenser jackets, respectively. The small amount of non-condensable gases was collected at the end of the condenser after a few minutes of operation. These gases are removed again by vacuum pump for perfect operation of thermosyphon. All of the residual working fluid in the test tube was collected after each run of experiment and its volume was measured to compare the exact quantity of working fluid. Only a data with no volumetric difference was taken.

The experimental conditions are set as follows. The heating and cooling water temperature are varied. Two constant water temperature baths support hot or cool water continuously within  $\pm 0.1^\circ\text{C}$  difference for each setting temperature. The temperature distribution, heat flux, boiling heat transfer coefficients are obtained with respect to number of grooves, temperature changes of heating water or cooling water and working fluids. An uncertainty analysis along the lines suggested by Kline and McClintock (1953) showed that the uncertainty due to measurement errors in the determination of  $q_e$  and  $q_c$  was about 3.9 and 5.0 percent, respectively. An uncertainty for the value of  $h_e$  at a  $\Delta T$  of 4.6 K is about 6.9 percent and that for the value of  $h_c$  at a  $\Delta T$  of 3.0 K is about 8.8 percent.

### 3. Results and Discussion

#### 3.1 Temperature distributions of outside wall of thermosyphon

Temperature distributions of the heated wall, adiabatic section and cooled wall on the thermosyphon with plain tube are shown in Fig. 4. Heating water temperature is  $60\sim 90^\circ\text{C}$  and liquid fill charge ratio is 30% in Fig. 4. The liquid fill charge ratio means the ratio of the volume of working fluid charged in the test thermosyphon to the total internal volume of the test thermosyphon.

The flow rates of heating and cooling water are fixed as  $0.4\text{ m}^3/\text{h}$  respectively. The working fluid used in Fig. 4 is methanol. The temperature difference between the heated and cooled wall using methanol as a working fluid are closer to adiabatic temperature compared to those when water are used as working fluid. When the heat flux is small, the rate of vapor generation due to evaporation and boiling in the heated section was small and condensate film flowing down onto heated wall then was so thin that it was apt to break down easily. On the contrary, as an increase of the heat flux raised the flow rate of the condensate film, the film became rather stable.

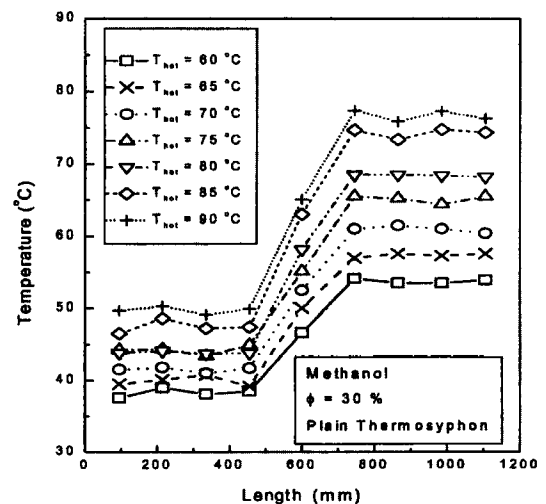

Fig. 4 Temperature distribution along the length of plain thermosyphon

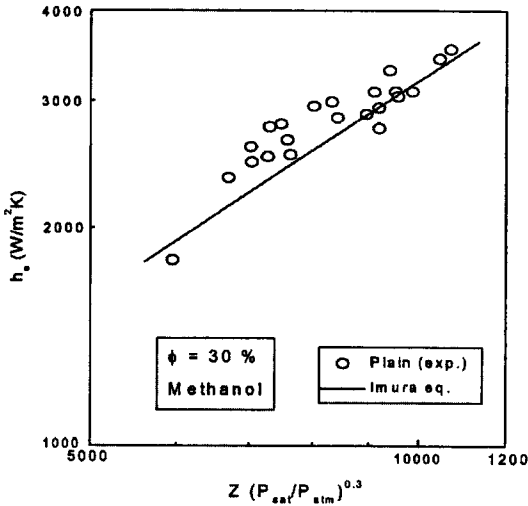

Fig. 5 Comparison of the experimental data with correlations by Imura' equation

### 3.2 Boiling heat transfer coefficient for the plain thermosyphon

Boiling heat transfer coefficients of plain thermosyphon are shown in Fig. 5. All the data of plain thermosyphon is correlated well with Imura's empirical relation (1977). Imura's correlation is represented below.

$$h_e = 0.32 Z \left( \frac{P_{sat}}{P_{atm}} \right)^{0.3} \quad (1)$$

$$\text{where } Z = \frac{\rho_l^{0.65} k_l^{0.3} c_{pl}^{0.7} g^{0.2} q_e^{0.4}}{\rho_v^{0.25} h_{fg}^{0.4} \mu_{pl}^{0.1}}$$

### 3.3 Boiling heat transfer coefficients for the grooved thermosyphons

The heat transfer process in the liquid pool is generally considered to be one of nucleate boiling. The boiling in the liquid pool differs somewhat from well-known pool boiling because the boiling in the thermosyphon occurs in a cavity and the motion of the vapor bubbles in the liquid pool is having a large effects on the heat transfer process. Purely theoretical study of the boiling in the evaporator is not possible due to the complexity of the process. Therefore, the heat transfer coefficient of the boiling was obtained empirically. The boiling in the two-phase closed thermosyphon is thought to be similar in heat transfer processes to the boiling which occurs in

Table 2 Parameters used in the experiments

Item	Range
Vapour pressure	0.2~1.2 bar
Heat flux of evaporator	20000~50000 W/m <sup>2</sup>
Number of grooves	50, 60, 70, 80, 90
Heating water inlet temperature	60°C ~ 90°C

the open thermosyphon except for the operating pressure. Generally, the former occurs at reduced pressure, the latter does at atmospheric pressure. For the latter boiling, the empirical heat transfer coefficient which is based on dimensional analysis has been described in the literature (1977). In this study, we applied their relation to the boiling of a closed thermosyphons with internal grooves. We assumed that the heat transfer process was the same as that occurred in the open thermosyphon and the boiling heat transfer coefficient of a closed thermosyphons with internal grooves was given by:

$$h_e(\text{grooved}) \propto h_e(\text{open}) \cdot (P_{sat}/P_{atm})^n \cdot A \sin \left( \pi \frac{(b/D_i) - (b/D_i)_c}{w} \right) \quad (2)$$

where  $P_{atm}$  is the atmospheric pressure.

The experiments are conducted with five grooved thermosyphons, i.e., 50, 60, 70, 80, 90 grooves. The parameters and their ranges of working conditions are presented in Table 2. From the experimental results, it is found that the ratio  $h_e(\text{grooved})/h_e(\text{open})$  increases with vapor pressure in the following relationship:

$$\frac{h_e(\text{grooved})}{h_e(\text{open})} \propto (P_{sat}/P_{atm})^{0.51} \quad (3)$$

as shown in Fig. 6. It is also reaffirmed that the temperature difference  $\Delta T$  and heat flux  $q$  have little effect on the ratio  $h_e(\text{grooved})/h_e(\text{open})$ .

From the experimental results, it is found that the ratio  $h_e(\text{grooved})/h_e(\text{Imura' eq.})$  shows sine function with  $b/D_i$  in the Fig. 7. The solid line was determined by a following relationship:

$$\frac{h_e(\text{grooved})}{h_e(\text{Imura})} \propto 2.34 \sin \left( \frac{\pi}{0.062} \frac{b}{D_i} \right) \quad (4)$$

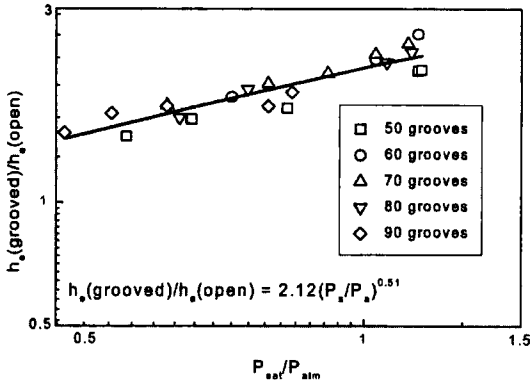

Fig. 6 Effects of the operating pressure on heat transfer coefficients. The solid line was determined by a least squares method

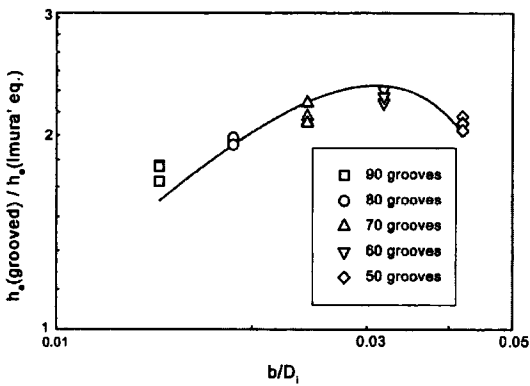

Fig. 7 Effects of the grooves on heat transfer coefficients. The solid line was determined by a least squares method.

The heat transfer coefficient of the boiling in the two-phase closed thermosyphons with various internal grooves was obtained as follows :

$$h_e = 0.75 \cdot Z \left( \frac{P_{sat}}{P_{atm}} \right)^{0.51} \sin \left( \frac{\pi}{0.062} \frac{b}{D_i} \right) \quad (5)$$

Figure 8 shows a good agreement between the experimental results and equation (5) for the five grooved thermosyphons.

Figure 9 shows comparison of the experimental results with equations (1) and (5). Experimental data are obtained with changes of heat input of evaporation section of thermosyphon. Boiling heat transfer coefficients increase as an increase of heat flux. All the data of grooved thermosyphons shows higher value than those of plain

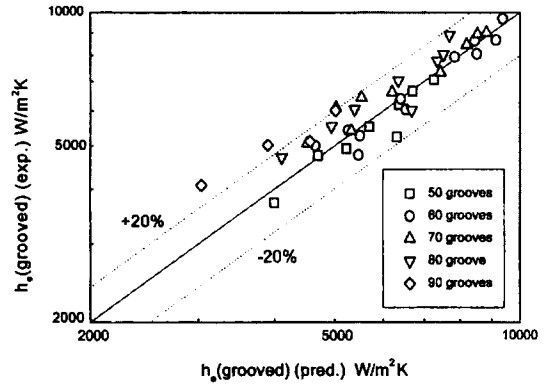

Fig. 8 Comparison of the experimental results with equation (5)

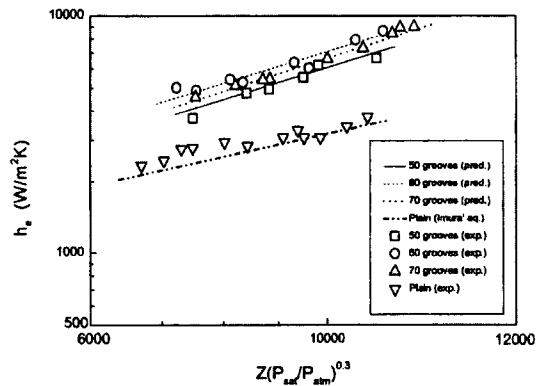

Fig. 9 Comparison of the experimental results with equations (1) and (5)

thermosyphon.

The best boiling heat transfer performance is obtained for 60 grooves, and the maximum value of this case is 2.5 times higher than that of the plain thermosyphon in methanol.

### 4. Conclusions

In this study, plain thermosyphon and the thermosyphons having 50, 60, 70, 80, 90 internal grooves are investigated for the comparison of heat transfer performance of low temperature closed thermosyphons. The conclusions of this study can be summarized as follows :

- (1) The boiling heat transfer coefficient of the plain thermosyphon were estimated from Imura's equation, in which  $h_e$  agreed with the experimental values.

(2) A mathematical model predicts the heat transfer characteristics closely and the agreement with the experimental results is good.

(3) The best boiling heat transfer performance is obtained for 60 grooves, and the maximum value of this case is 2.5 times higher than that of the plain thermosyphon.

## References

Andros, F. E., 1980, "Heat Transfer Characteristics of the Two-Phase Closed Thermosyphon (Wickless Heat Pipe) Including Direct Flow Observation," Ph. D. Thesis, Arizona State University.

Cohen, H. and Bayley, F. J., 1955, "Heat Transfer Problem of Liquid Cooled Gas Turbine Blades," Proc. Inst. Mech. Eng., 169-20, pp. 1063~1080.

Gaugler, R. S., 1942, "Heat Transfer Device," US Patent No. 2350348, US Patent Application. Dec. 21.

Hashimoto, H., Kaminaga, F. and Matsumura, K., 1999, "Study on Condensation Heat Transfer Characteristics in a Thermosyphon with Non-Condensable Gas Effect," 11th IHPC, Vol. 1, pp. 121~126.

Hong, J., Boo, J. and Jung, Y., 1988, "Experimentson the Thermal Performance of a Thermosyphon in Inner Grooved Copper Tube," Proc. SAREK Summer Conf., pp. 313~317.

Imura, H., Kusuda, H., Ogata, J. I., Miyaz, T. and Sakamoto, N., 1977, "Heat Transfer in Two-Phase Closed-Type Thermosyphons," *Trans. of*

*Japan Soc. of Mech. Engrs.*, pp. 485~493.

Kim, W. T., Song, K. S. and Lee, Y., 1998, "Design of a Two-Phase Loop Thermosyphon for Telecommunication System (I) — Experimentals and Visualization —," *KSME Int. J.*, Vol. 12, No. 5, pp. 926~941.

Kim, W. T., Song, K. S. and Lee, Y., 1998, "Design of a Two-Phase Loop Thermosyphon for Telecommunication System (II) — Experimentals and Visualization —," *KSME Int. J.*, Vol. 12, No. 5, pp. 942~955.

Kline, S. J. and McClintock, F. A., 1953, Describing Uncertainties in Single-Sample Experiments, Mechanical Engineering, Vol. 75, pp. 3~8.

Larkin, B. S., 1971, "A Experimental Study of the Two Phase Thermosyphon Tube," *Trans. Canda. Soc. Mech. Engrg.*, 14-B6, pp. 1~8.

Lee, B. I. and Lee, S. H., 2001, "Manufacturing and Temperature Measurements of a Sodium Heat Pipe," *KSME Int. J.*, Vol. 15, No. 11, pp. 1533~1540.

Lee, Y. and Mital, U., 1972, "A Two-Phase Closed Thermosyphon," *Int. J. of Heat and Mass Transfer*, 15-9, pp. 1695~1707.

Peterson, G. P. and Ma, H. B., 1996, "Experimental Investigation of the Maximum Heat Transport in Triangular Groove," *ASME J. of Heat Transfer*, Vol. 35, No. 3, pp. 740~746.

Stret'stov, A. I., 1975, "Theoretical and Experimental Investigation of Optimum Filling for Heat Pipes," *Heat Transfer, Soviet Research*, Vol. 7, No. 1, pp. 23~27.